

A

AKDENİZ ÜNİVERSİTESİ
YABANCI UYRUKLU-YURT DIŞINDAN
ÖĞRENCİ KABUL SINAVI



AKDENİZ UNIVERSITY INTERNATIONAL STUDENTS
ADMISSION EXAMINATION

14 Haziran 2013

ADAYIN / APPLICANT'S
ADI / NAME :
SOYADI / SURNAME :
ADAY NUMARASI / CANDIDATE NUMBER :
SINAV SALON NO / EXAMINATION ROOM NO :

GENEL AÇIKLAMA
(GENERAL INSTRUCTIONS)

- Bu sınavdaki soruların nasıl cevaplanacağı, testlerin başında açıklanmıştır. Soruları cevaplamaya başlamadan önce bu açıklamaları dikkatle okuyunuz.**
 - Bu testlerdeki her sorunun bir tek doğru cevabı vardır. Bir soru için birden çok cevap yeri işaretlenmişse, o soru yanlış cevaplanmış sayılacaktır.**
 - Cevaplarınızı koyu siyah ve yumuşak bir kurşun kalemle işaretleyiniz. İşaretlerinizi cevap yerinin dışına taşırmayınız. Tükenmez kalem veya dolma kalem kullanmayınız.**
 - Cevap kâğıdınızı buruşturmayınız, katlamayınız ve üzerine gereksiz hiçbir işaret koymayınız.**
 - Değiştirmek istediğiniz bir cevabı, yumuşak bir silgiyle, cevap kâğıdını örselemeden, temizce siliniz ve yeni cevabınızı işaretlemeyi unutmayınız.**
 - Bu testler puanlanırken, doğru cevaplarınızın sayısından yanlış cevaplarınızın sayısının dörtte biri düşülecek ve kalan sayı ham puanınız olacaktır. Bu nedenle, hakkında hiçbir fikriniz olmayan soruları boş bırakınız.**
 - Sınavda uyulacak diğer kurallar bu kitapçığın arka kapağında belirtilmiştir.**
- In these tests there is only one correct answer for each question. If more than one alternative is marked, that answer will automatically be considered wrong.
 - You should use a soft, black pencil to mark the answer sheet. Completely fill in the circle for the answer you have chosen, but make sure your mark does not go beyond the borders of the circle. Do not use any kind of pen.
 - Keep the answer sheet flat and do not fold it. Do not make any unnecessary marks on it.
 - If you wish to change an answer, carefully erase it completely with a very soft eraser. Do not forget to mark your new answer.
 - In the scoring of the tests, for every four incorrect answers, one correct answer will be deducted; the remainder will be the raw score. With this in mind, do not guess at the answers.
 - The other regulations concerning the administration of the tests will be found at the back of the booklet.

- The instructions for answering the questions appear at the beginning of the tests. Please read these carefully before beginning.



$$1) \frac{1}{2} - \left(\frac{1}{5} - \frac{1}{10} \right) - \left(\frac{1}{2} - \frac{1}{10} + \frac{1}{5} \right) = ?$$

- A) $-\frac{1}{5}$ B) $\frac{1}{5}$ C) $\frac{11}{10}$
 D) 0 E) $-\frac{11}{10}$

$$2) \left[\left(\frac{0,025}{0,05} \right) : \left(\frac{1}{2} - 1 \right) \right]^{-\frac{1}{3}} = ?$$

- A) 0 B) 1 C) -1
 D) 2 E) -2

$$3) \frac{\sqrt{2,25} - \sqrt{1,96}}{\sqrt{0,09} - \sqrt{0,16}} = ?$$

- A) -2 B) -1 C) 0
 D) 1 E) 2

$$4) \sqrt{x+1} = \sqrt[3]{x+1} \text{ eşitliğini}$$

sağlayan x'lerin çarpımı nedir?

According to the equation, what is the value of multiplication of x's?

- A) -1 B) 0 C) 1
 D) 2 E) 3

$$5) x+y = -2$$

$$a-b = -1$$

$$bx+by-ax-ay = ?$$

- A) 1 B) 2 C) 3
 D) -2 E) -3

$$6) a = 3 + \sqrt{3}$$

$$b = \frac{\sqrt{3a^4} \sqrt{a^2}}{\sqrt{3} + \sqrt[3]{27}} \quad b = ?$$

- A) $3\sqrt{a}$ B) $a\sqrt{3}$ C) $3\sqrt{3}$
 D) $2\sqrt{3}$ E) $\sqrt{3}$

$$7) 2 - \frac{1}{2 - \frac{1}{2 - \frac{1}{2 - \frac{1}{2 - \dots}}}} = ?$$

- A) 1 B) $\frac{3}{2}$ C) $\frac{1}{2}$
 D) $\frac{5}{3}$ E) $\frac{4}{3}$

$$8) \frac{\left[(4)^{-2} : \left(-\frac{1}{3} \right)^2 \right]^{\frac{1}{2}}}{\left(-\frac{1}{6} \right)^2} = ?$$

- A) 27 B) -27 C) 48
 D) -36 E) 36

9) $a = \sqrt{(\sqrt{3} - \sqrt{5})^2}$

$b = \sqrt{(\sqrt{5} - \sqrt{3})^2}$

$a - b = ?$

- A) $-2\sqrt{5}$ B) $2\sqrt{5}$ C) $-2\sqrt{3}$
 D) $2\sqrt{3}$ E) 0

10) $\frac{\sqrt[3]{a^2 + a}}{\sqrt[3]{a + a}} - \frac{\sqrt[3]{a} - 1}{\sqrt[3]{a^2 + 1}} = ?$

- A) a B) \sqrt{a} C) $\sqrt[3]{a}$
 D) 1 E) -1

11) $\frac{x + y}{x - y} = \frac{3}{5}$

$xy = -4$

ise y 'nin alabileceği değerlerin çarpımı nedir?

According to the equation system above, what is the multiplication of the values of y ?

- A) 4 B) 2 C) -2
 D) -1 E) 1

12) $x - y + 2z = 2$

$x - y + z = 2$

$x + y - z = 0$

$y = ?$

- A) -2 B) 2 C) 0
 D) 1 E) -1

13)

$\left(1 - \frac{1}{2^2}\right) \cdot \left(1 - \frac{1}{3^2}\right) \cdot \left(1 - \frac{1}{4^2}\right) \cdot \dots \cdot \left(1 - \frac{1}{10^2}\right) = ?$

- A) $\frac{9}{20}$ B) $\frac{11}{10}$ C) $\frac{11}{20}$
 D) $\frac{9}{10}$ E) $\frac{10}{11}$

14) $\frac{(a + b)^2 - ab}{a^3 - b^3} : \frac{a^2 + ab}{a^2 - b^2} = ?$

- A) $a + b$ B) $\frac{1}{a - b}$ C) $\frac{1}{a}$
 D) b E) a

21) $f^{-1}(x) = x-1$
 $g(x) = x^2 + 2x$
 $(f \circ g)(1) = ?$

- A) 0 B) 1 C) 2
 D) 3 E) 4

22) $f(x) = \sin 2x + \cos^2 2x$
 $f^{-1}\left(\frac{\pi}{4}\right) = ?$

- A) -2 B) -1 C) 0
 D) 1 E) 2

23) $3x^3 - x - 2y^2 = 0$

$$\left. \begin{array}{l} \frac{dy}{dx} \\ x=1 \\ y=2 \end{array} \right| = ?$$

- A) -2 B) -1 C) 1
 D) 2 E) 0

24) $f(x) = x^3 + x$

$$\lim_{x \rightarrow 1} \frac{f(x) - f(1)}{1 - x} = ?$$

- A) -4 B) -3 C) -2
 D) -1 E) 0

25) $\lim_{x \rightarrow \frac{\pi}{4}} \frac{1 - \sqrt{2} \sin x}{\cot^2 x - 1} = ?$

- A) $-\frac{1}{4}$ B) $\frac{1}{4}$ C) 0
 D) $\frac{1}{2}$ E) $-\frac{1}{2}$

26) $\lim_{x \rightarrow 0} \frac{2x}{\tan 3x} = ?$

- A) $-\frac{1}{2}$ B) $\frac{1}{2}$ C) $-\frac{3}{2}$
 D) $\frac{2}{3}$ E) $\frac{3}{2}$

27) $\lim_{x \rightarrow \infty} \frac{\ln x}{x^2 + 1} = ?$

- A) ∞ B) 0 C) 1
 D) -1 E) $-\infty$

28) $\frac{\sin 205}{\cos 65} + \frac{\tan 40}{\tan 140} = ?$

- A) $-\frac{1}{2}$ B) $\frac{1}{2}$ C) -1
 D) -2 E) 0

29) $\int_e^{e^2} \frac{dx}{x \ln x} = ?$

- A) $\ln(e-2)$
- B) $\ln 2$
- C) $\ln(e^2 - e)$
- D) 1
- E) 0

30) $\int_1^7 \frac{dx}{x^2 + 7x} = ?$

- A) $-\frac{4}{7} \ln 2$
- B) $\frac{1}{7} \ln 2$
- C) $\frac{2}{7} \ln 2$
- D) $\frac{3}{7} \ln 2$
- E) $\frac{7}{3} \ln 2$

31) $\int_0^1 \frac{dx}{x^2 + 1} = ?$

- A) 0
- B) 1
- C) $\frac{\pi}{4}$
- D) $\frac{\pi}{2}$
- E) $\frac{3\pi}{4}$

32) $\int \frac{\cos(e^{-x})}{e^x} dx = ?$

- A) $\sin(e^{-x}) + c$
- B) $\cos(e^{-x}) + c$
- C) $-\cos(e^{-x}) + c$
- D) $e^{-x} \cos(e^{-x}) + c$
- E) $-\sin(e^{-x}) + c$

33)

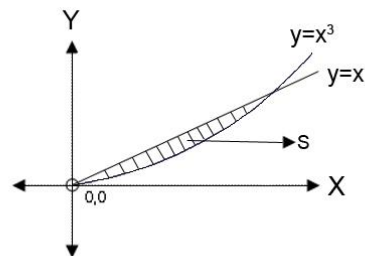

S=? br² (unit square)

- A) $\frac{1}{4}$
- B) $\frac{1}{2}$
- C) 1
- D) $\frac{3}{2}$
- E) 2

34) $\int_1^e \frac{d}{dx} (2^x - \ln x) dx = ?$

- A) $2^e - 1$
- B) $2^e - 3$
- C) 2^e
- D) $2^e + 1$
- E) $2^e + 2$

35) $z_1 = 1 + i$

$z_2 = 2 - i$

$\left| \frac{z_1}{z_2} \right| = ?$

- A) $\frac{2}{\sqrt{5}}$ B) $\frac{\sqrt{2}}{\sqrt{5}}$ C) $\sqrt{5}$
D) $\frac{\sqrt{5}}{2}$ E) $\frac{\sqrt{5}}{\sqrt{5}}$

36) $i^2 = -1$

$i^{2012} - i^{2013} + i^{2014} - i^{2015}$

- A) $-i$ B) i C) 0
D) 1 E) -1

37) $\left(-\frac{1}{2}\right)^{1-2n} (-2)^{2n+1} \left(\frac{1}{8}\right)^{-n} = 128$

$n = ?$

- A) -2 B) -1 C) 0
D) 1 E) 2

38) $A = \begin{bmatrix} a & b \\ c & d \end{bmatrix}$, $\det(A) = |A| = 5$

$B = \begin{bmatrix} 3a - b & 4b \\ 3c - d & 4d \end{bmatrix}$, $\det(B) = |B| = ?$

- A) 5 B) 15 C) 20
D) 40 E) 60

39) $n \in \mathbb{N}$ (N is set of natural numbers.)

$6^{2n+4} + 2^{3n+2} + 6 \equiv ? \pmod{7}$

- A) 2 B) 3 C) 4
D) 5 E) 6

40) $x + y \equiv 6 \pmod{7}$

$3x - y \equiv 2 \pmod{7}$

$x - y \equiv ? \pmod{7}$

- A) 2 B) 3 C) 4
D) 5 E) 6

41)

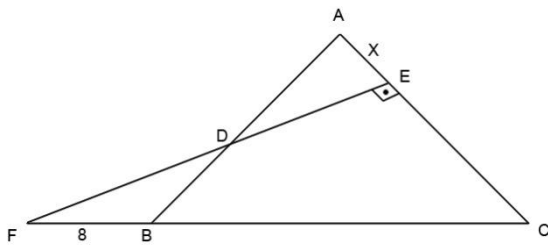

$$|AB| = |BC| = |AC|$$

$$[FE] \perp [AC]$$

$$|FB| = 8 \text{ cm}$$

$$|AC| = 12 \text{ cm}$$

$$|AE| = x = ?$$

- A) 6 B) 5 C) 4
D) 3 E) 2

42)

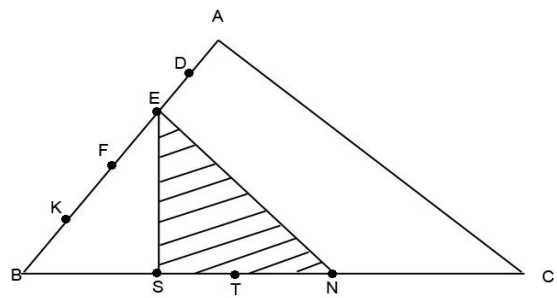

$$|AD| = |DE| = |EF| = |FK| = |KB|$$

$$|BS| = |ST| = |TN| = |NC|$$

$$A(S \hat{N} E) / A(A \hat{B} C) = ?$$

- A) $\frac{5}{7}$ B) $\frac{4}{7}$ C) $\frac{3}{7}$
D) $\frac{1}{5}$ E) $\frac{3}{10}$

43)

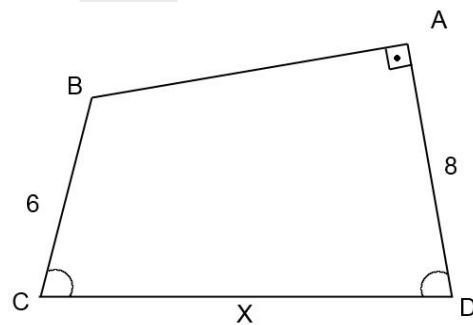

$$|AD| = 8 \quad |BC| = 6$$

$$s(\hat{C}) = s(\hat{D}) = 60^\circ$$

$$|CD| = X = ?$$

- A) 8 B) 10 C) 12
D) 14 E) 15

44)

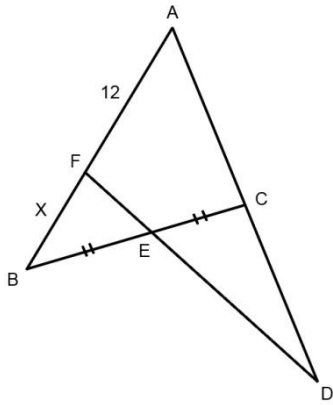

$$|AC| = 2|CD|$$

$$|BE| = |EC|$$

$$|AF| = 12\text{cm}$$

$$|FB| = X = ?$$

A) 2

B) 3

C) 4

D) 5

E) 6

45)

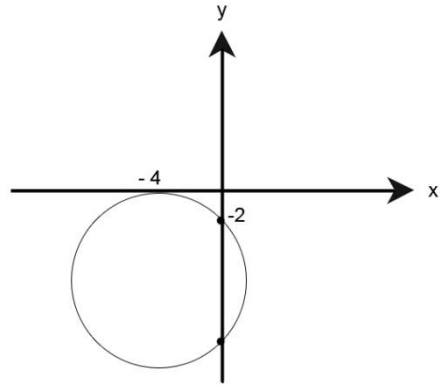

Çemberin denklemini bulunuz.

Find the equation of the circle.

A) $(x+4)^2 + (y+5)^2 = 25$

B) $(x+4)^2 + (y-5)^2 = 25$

C) $(x+2)^2 + (y-5)^2 = 16$

D) $(x-4)^2 + (y+5)^2 = 25$

E) $(x-3)^2 + (y-5)^2 = 20$

46)

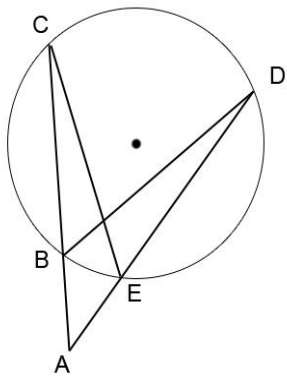

$$m(\hat{A}) = 20^\circ$$

$$m(\hat{CBD}) = 85^\circ$$

$$m(\hat{BCE}) = ?$$

A) 55

B) 60

C) 65

D) 70

E) 75

47)

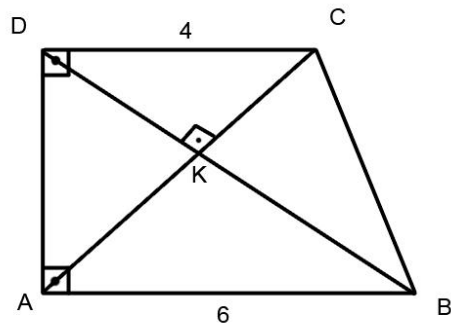

$$|AB| = 6 \text{ cm}$$

$$|DC| = 4 \text{ cm}$$

$$A(ABCD) / A(\triangle DKC) = ?$$

A) $\frac{25}{2}$

B) $\frac{25}{3}$

C) $\frac{35}{2}$

D) $\frac{25}{4}$

E) $\frac{35}{8}$

48)

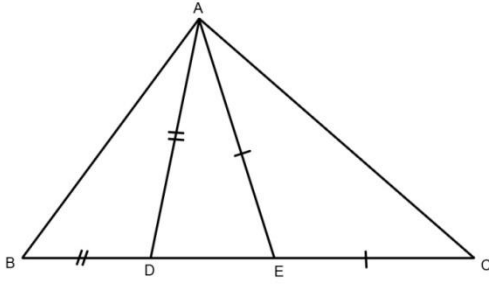

$$|AE| = |EC|$$

$$|AD| = |BD|$$

$$m(\angle DAE) = 26^\circ$$

$$m(\angle B\hat{A}C) = ?$$

- A) 103 B) 105 C) 110
D) 115 E) 120

49) $d_1: 2x - ty - 5 = 0$

$$d_2: -2x - 8y + 3 = 0$$

$$d_1 // d_2$$

$$t = ?$$

- A) 4 B) 6 C) 8
D) -6 E) -8

50) $\vec{u} = [-5, 12]$ vektörüne dik olan birim vektör hangisidir?

- A) $[12, 5]$ B) $\left[-\frac{12}{13}, \frac{5}{13}\right]$ C) $\left[-\frac{5}{13}, \frac{12}{13}\right]$
D) $\left[-\frac{5}{13}, -\frac{12}{13}\right]$ E) $\left[-\frac{12}{13}, -\frac{5}{13}\right]$

51-53. sorularda her harf birbirinden farklı bir şekle karşılık gelmektedir.

In questions 51-53, there is a different symbol to represent each letter.

51)

⊗	△	□	○	□	△	●
△	○	□	⊗	○	△	□
●	□	△	○	□	□	⊗
□	△	○	□	△	⊗	●
⊗	○	△	□	△	○	□
○	□	●	□	○	△	⊗
⊗	△	□	○	⊗	○	●

1

2

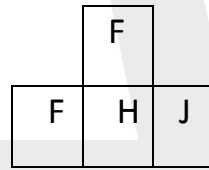
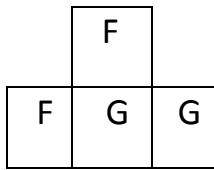

F= ○

G= □

H= ? J= ?

1 ve 2, yukarıdaki tablonun farklı birer parçanıdır. Buna göre, 2'deki H ve J' nin yerine aşağıdakilerden hangisi gelmelidir?

1 and 2 are different parts of the figure above. Accordingly, which of the following combinations should replace H and J in 2?

- | | <u>H</u> | <u>J</u> |
|----|----------|----------|
| A) | ● | △ |
| B) | △ | ● |
| C) | ⊗ | ● |
| D) | △ | ⊗ |
| E) | ⊗ | △ |

52)

□	△	⊗	□	☆	⊗	○
☆	○	□	⊗	⊗	⊗	□
○	⊗	⊗	○	⊗	☆	○
○	⊗	⊗	□	△	○	☆
⊗	○	⊗	□	△	○	△
☆	□	⊗	⊗	○	△	⊗
□	○	⊗	△	⊗	☆	⊗

1

2

	⊗	F
G	G	

J	F
F	H

F= ○

G= ⊗

H= ?

J= ?

1 ve 2, yukarıdaki tablonun farklı birer parçasıdır. Buna göre, 2'deki H ve J' nin yerine aşağıdakilerden hangisi gelmelidir?

1 and 2 are different parts of the figure above. Accordingly, which of the following combinations should replace H and J in 2?

- | | <u>H</u> | <u>J</u> |
|----|----------|----------|
| A) | ⊗ | ☆ |
| B) | △ | ☆ |
| C) | □ | △ |
| D) | △ | □ |
| E) | □ | □ |

53)

△	□	☆	○	●	⊗	⊗
☆	○	⊗	△	●	⊗	□
□	☆	●	⊗	□	○	△
⊗	●	⊗	□	⊗	△	☆
⊗	○	△	●	□	☆	○
□	●	□	⊗	⊗	☆	△
●	△	⊗	○	☆	⊗	□

1

2

F	G
G	F

F	H	F
	J	

F= X G=

H=? J=?

1 ve 2, yukarıdaki tablonun farklı birer parçasıdır. Buna göre, 2'deki H ve J' nin yerine aşağıdakilerden hangisi gelmelidir?

1 and 2 are different parts of the figure above. Accordingly, which of the following combinations should replace H and J in 2?

- | | <u>H</u> | <u>J</u> |
|----|----------|----------|
| A) | ⊗ | △ |
| B) | ○ | ● |
| C) | △ | ⊗ |
| D) | ⊗ | ● |
| E) | ● | ○ |

54) Aşağıdaki verilen parçalar kullanarak oluşturulan şekli bulunuz.

Find the figure using given fragments.

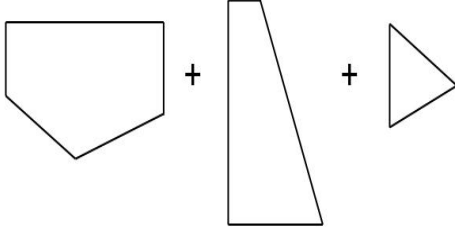

A)

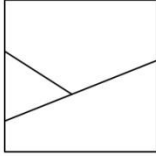

B)

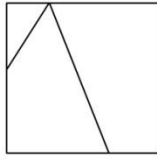

C)

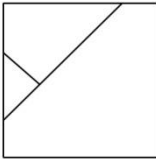

D)

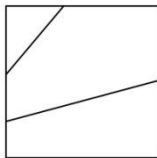

E)

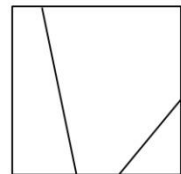

55-57. soruları aşağıdaki şekle göre cevaplayınız.

Her soru birbirinden bağımsız olarak cevaplanacaktır.

Answer questions 55-57 in accordance with the figure given below.

m^k	$k.l$	n^l
	k	l
	m	n
$\frac{k}{m}$	$m.n$	$\frac{l}{n}$

Yukarıdaki şekil k,l,m ve n harfleriyle gösterilen dört pozitif tamsayıyı içeren bazı işlemlere göre düzenlenmiştir. Harflerin gösterdiği sayılar her soruda farklı olabilir ancak bunlarla yapılacak işlemler her soruda aynıdır.

The figure above has been organized according to various operations using four positive integers represented by letters, k, l, m, and n. The integers represented by the letters may change from questions, but the operations to be done remain the same.

55)

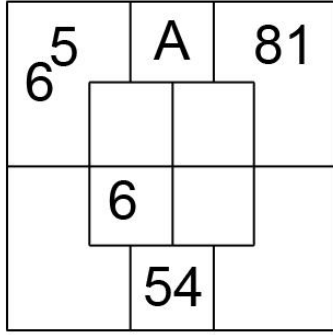

Yukarıdaki verilen şekle göre A kaçtır?

According to the figure above, what is the value of A?

- A) 8 B) 9 C) 10
D) 11 E) 12

56)

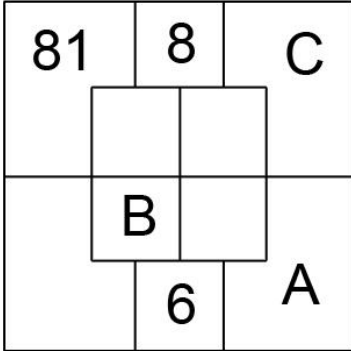

A+B+C=?

Yukarıda verilen şekle göre A+B+C=?

According to the figure above, what is the value of A+B+C=?

- A) 8 B) 9 C) 10
D) 11 E) 12

57)

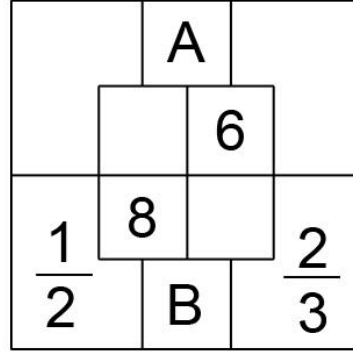

A+B=?

Yukarıda verilen şekle göre A+B=?

According to the figure above, what is the value of A+B=?

- A) 90 B) 96 C) 102
D) 108 E) 114

58)

x	a	b
a	4a+5	
b		16a-1

b=?

Yukarıdaki çarpma tablosunda a ve b harfleri pozitif birer tamsayının yerine kullanılmıştır. Buna göre b kaçtır?

In the multiplication table above, the letters a and b each stand for a positive number. Accordingly, what is the value of b?

- A) 6 B) 7 C) 8
D) 9 E) 10

59)

x	a	b	c
a			
b		$\frac{3}{2}a$	
c		32	6a

b=?

Yukarıdaki çarpma tablosunda a, b ve c harfleri pozitif bir sayının yerine kullanılmıştır. Buna göre b kaçtır?

In the multiplication table above, the letters a,b and c stand for a positive number. Accordingly, what is the value of b?

- A) 4 B) 5 C) 6
D) 7 E) 8

60)

x	a	b	c
a			
b			12b

+	a	b	c
a		2c	
b			5a

b=?

Yukarıdaki çarpma ve toplama tablosunda a,b,c harfleri pozitif birer sayının yerine kullanılmıştır. Buna göre b kaçtır?

In the multiplication and addition tables above, the letters a, b and c each stand for a positive number. Accordingly, what is the value of b?

- A) 6 B) 12 C) 14
D) 16 E) 18

61)

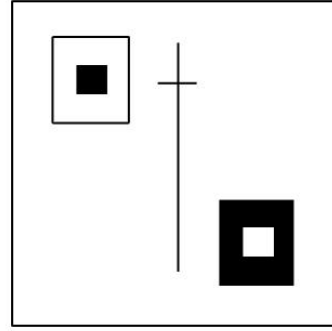

Aşağıda verilen şekillerden hangisi yukarıdaki şeklin döndürülmüş halidir?

Which of the figures below is the turned shape of the given one?

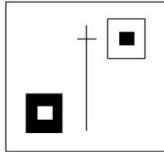
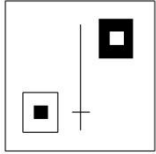
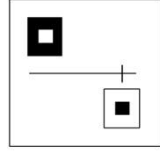
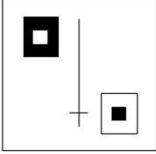
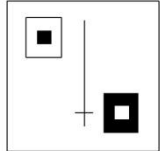
- A)  B) 
- C)  D) 
- E) 

62 ve 63.sorularda 1. Satırda belirlenen ilişkiye göre 2. Satırda hangi şeklin tamamlandığını bulunuz.

In questions 62-63, find the figure which completes row 2 in accordance with the relationship established in row 1.

62)

- 1 -

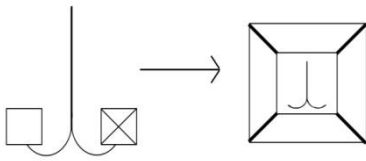

- 2 -

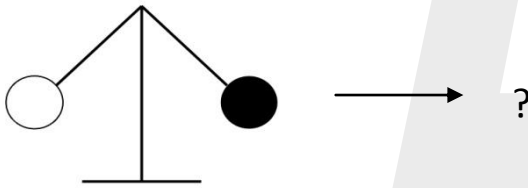

A)



B)

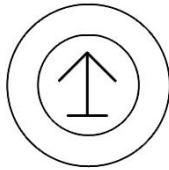

B)

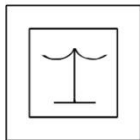

D)

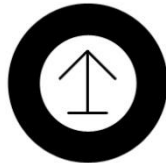

E)

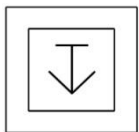

63)

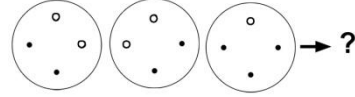
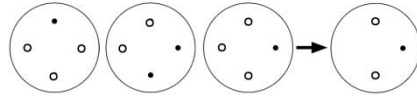

A)



B)



C)



D)



E)



64)

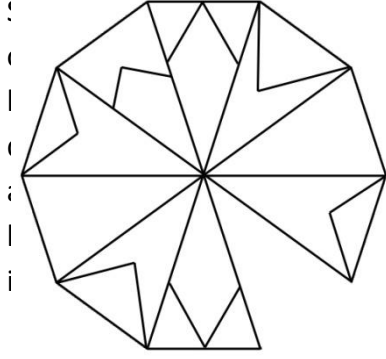

Ş
ekilde eksik olan parça hangisidir?
What is the missing part in the
figure on the left?

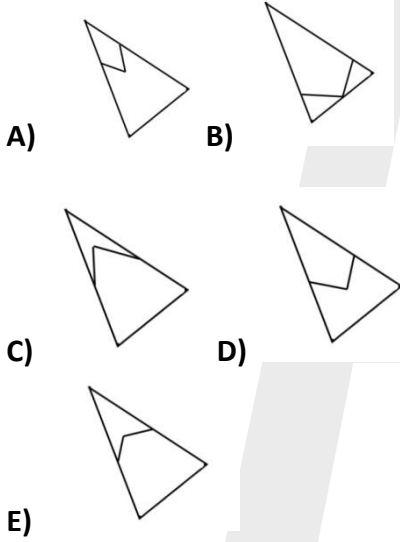

65)

Yandaki küplerden oluşmuş
şeklin tabanı hariç tüm yüzey
k

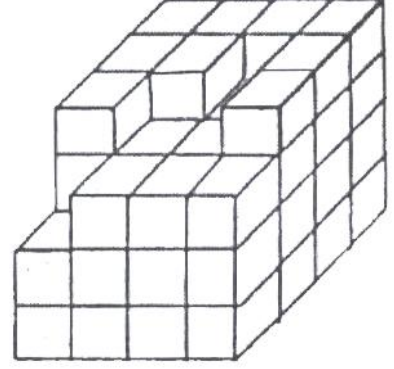

e
boyanmıştır. Buna göre sadece
3 yüzü boyalı olan kaç küp
vardır?

All surfaces except its base of
the figure composed of cubes
on the left was painted in red.
According to this, how many
cubes which have only 3
painted surfaces are there?



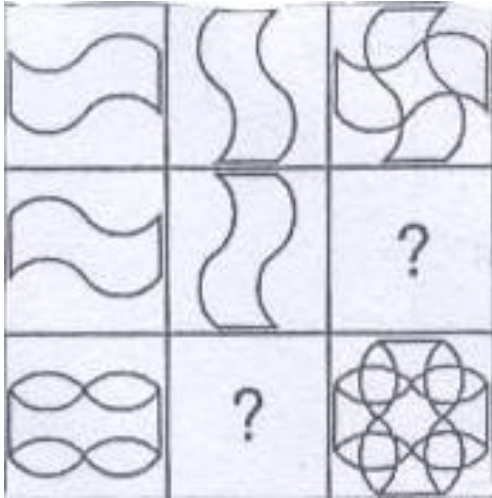

- A) 10 B) 9 C) 8
D) 7 E) 6

66)

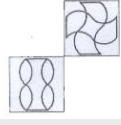

Boş karelere gelmesi gereken şekilleri bulunuz.

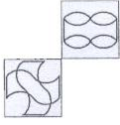
Find the figures that must be placed in the empty squares.

- A)  B) 
- C)  D) 
- E) 

67)

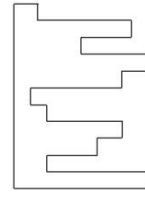

Soldaki şekli kare olarak tamamlayacak şekli bulunuz?

Find the figure which makes the given figure on the left a square.

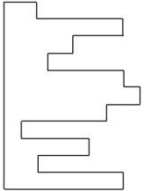
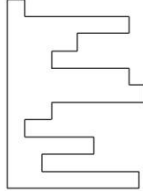
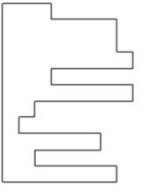
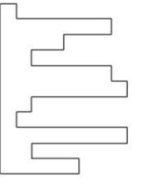
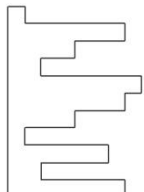
- A)  B) 
- C)  D) 
- E) 

68)

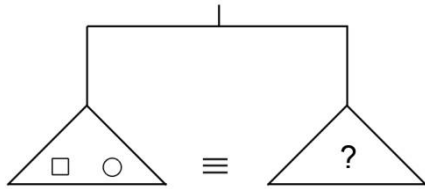
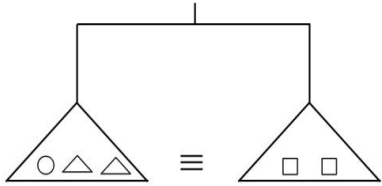
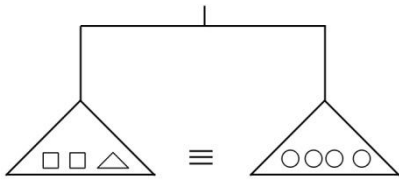

- A) $\Delta O \square$ B) $O \Delta$ C) $\Delta \square$
 D) $\square \square$ E) $O O \Delta$

69)

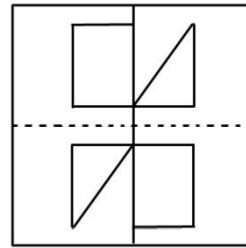

Yandaki şekil kesikli çizgi etrafında katlanırsa, hangi şekil ortaya çıkar?

If the figure on the left is folded on the dashed line, which figure occurs?

dashed line, which figure occurs?

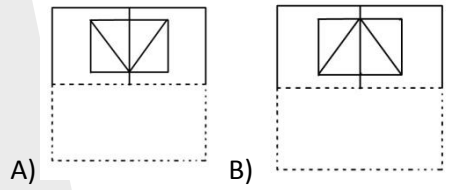

A)

B)

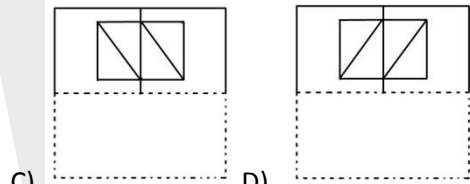

C)

D)

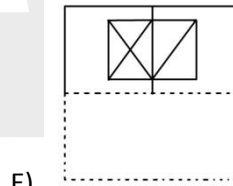

E)

70. Soruyu örnekte verilen ilişkiye göre cevaplayınız.

Find the correct answer in accordance with the relationship established in the example below.

ÖRNEK

EXAMPLE

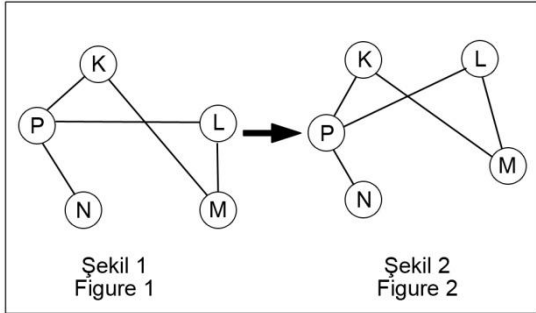

K,L,M,N ve P harfleri 1. şekildeki gibi birbirine bağlanmıştır. 1. şekildeki bağlantı sayıları ve birbirine bağlanan harfler değişmemek koşuluyla 2. şekil elde edilmiştir.

Letters K,L,M,N and P are linked as in Figure 1. Figure 2 has been constructed so as not to change which letters are linked to which, and the number of links made with each letter, in Figure 1.

70)

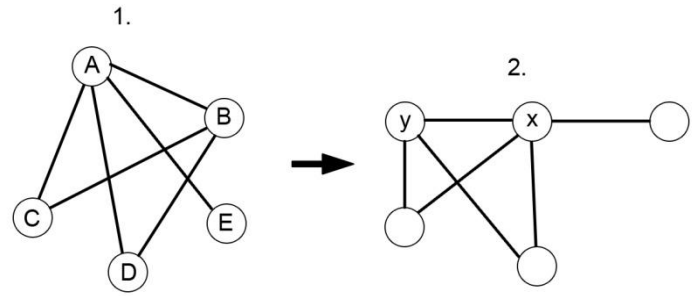

X =? Y =?

2. şekilde x ve y'nin yerine gelmesi gereken harfleri bulunuz.

Find the letters that correspond to x and y in Figure 2.

- | | X | Y |
|---------|--------|------|
| A)..... | E..... | C... |
| B)..... | B..... | A... |
| C)..... | C..... | E... |
| D)..... | A..... | B... |
| E)..... | D..... | C... |

71)

$$a*b = \begin{cases} a-b, & a \leq b \\ a+b, & a > b \end{cases}$$

(2*0)*(1*3)=?

- A) 4 B) -4 C) 0
D) -2 E) 2

72)

$$X \star y = x^y$$

$$X \blacktriangle y = x+y$$

$$X \star (x \blacktriangle 1) = 81 \implies x=?$$

- A) 2 B) 3 C) 4
D) 8 E) 1

73.-74. Soruları aşağıdaki tabloya göre cevaplayınız.

Answer the questions 73-74 according to the table below.

\blacktriangle	e	a	b	c	d
e	e	a	b	c	d
a	b	b	c	d	e
b	c	c	d	e	a
c	c	d	e	a	b
d	d	e	a	b	e

73) $(a \blacktriangle b) \blacktriangle (e \blacktriangle c) = ?$

- A) a B) b C) c
D) d E) e

74) $(x \blacktriangle a) \blacktriangle a = d \implies x=?$

- A) a B) b C) c
D) d E) e

75)

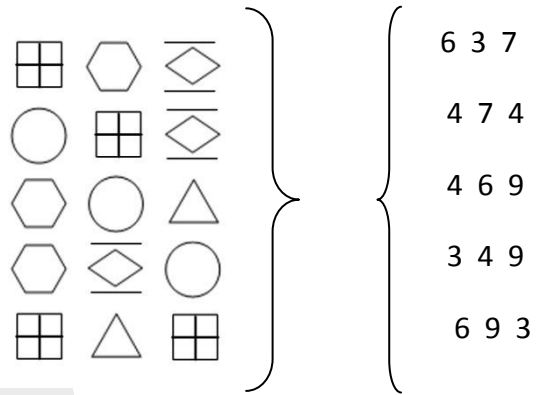

- A) 736 B) 763 C) 697 D) 679 E) 976

76) $\sum_{k=1}^6 (2k + p) = 66$

P=?

- A) -2 B) 0 C) 2
D) 4 E) 6

77) $\prod_{k=2}^{10} \frac{k-1}{k+1} = ?$

- A) $\frac{1}{55}$ B) $\frac{1}{110}$ C) $\frac{2}{55}$
D) $\frac{2}{11}$ E) $\frac{1}{101}$

78)

$$f(x) = \begin{cases} x^2 - 1, & x < -1 \\ \frac{1}{2}x + \frac{1}{2}, & x \geq -1 \end{cases}$$

Yukarıdaki fonksiyonun grafiği hangisidir?

Find the graph of $f(x)$

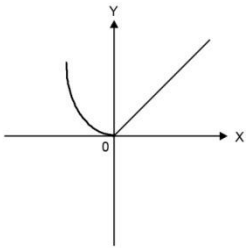

A)

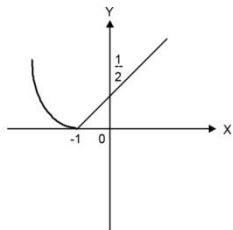

B)

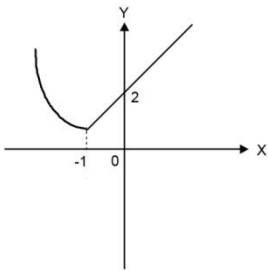

C)

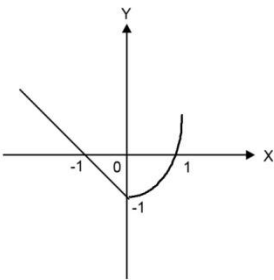

D)

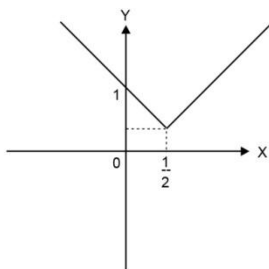

E)

79) $A = \begin{bmatrix} 2 & 5 \\ 3 & 7 \end{bmatrix}$

$A + A^{-1} = ?$

A) $\begin{bmatrix} 7 & 5 \\ 3 & 2 \end{bmatrix}$

B) $\begin{bmatrix} 9 & 0 \\ 0 & 9 \end{bmatrix}$

C) $\begin{bmatrix} -5 & 10 \\ 6 & 5 \end{bmatrix}$

B) $\begin{bmatrix} 7 & 5 \\ 10 & -9 \end{bmatrix}$

E) $\begin{bmatrix} -5 & -6 \\ 10 & 3 \end{bmatrix}$

80)

$$\begin{pmatrix} 1 & 3 & 4 \\ 4 & 1 & 3 \\ 4 & 0 & 1 \end{pmatrix} \times \begin{pmatrix} 2 & 1 & -7 \\ 4 & 5 & 6 \\ 0 & 2 & 1 \end{pmatrix} = \begin{pmatrix} x & . & . \\ . & . & y \\ . & . & . \end{pmatrix}$$

$x + y = ?$

A) -19

B) -5

C) 0

D) 14

E) 16





RULES TO BE FOLLOWED

1. It's strictly forbidden to bring cellular (mobile) phones into the examination hall. Also forbidden are any other kind of electronic or communications equipment (other than watches that only show time), weapons, explosive materials, scrap paper, notebooks, books, dictionaries and related instruments, slide-rules, compasses, protractors, rulers, and the like.
2. The time given to answer the items in this examination is **100 minutes**.
3. Applicants who have left the examination hall, having handed in their answer books may not return.
4. After the examination starts, no candidate will be allowed to leave the examination hall during the first 30 minutes and during the last 15 minutes.
5. If you finish answering the questions early (that is, after the 30 minutes but before the last 15 minutes of given time for the test), you may hand in your answer sheet, test booklet and Examination Entrance Card and identification card to a person in charge and leave the examination hall.
6. During the test, it is forbidden to ask questions of or talk to those persons in charge. It is also against the rules of the examination for people in charge to converse or whisper to any candidates. Similarly, it is forbidden to ask another candidate for a pencil, eraser, or anything else.
7. During the examination, candidates are required to comply with all the directions given to them by the people in charge, who have the right to tell a candidate to change his/her seat. You must obey all instructions given to you. Otherwise, your name and application number will be taken, and your examination will be cancelled.
8. If during the test anyone is found cheating, trying to cheat, or helping someone else to cheat, his/her name and application number will be recorded, and his/her answer sheet will not be considered for evaluation. The people in charge are in no way required to warn candidates about cheating. This is the candidates' responsibility. During the examination, it is extremely important that you exercise extreme care in not letting your answer sheet be seen by another candidate.
9. It is important to fill in the necessary areas on the answer sheet. You must use only a soft lead pencil for writing your name and other information or marking answers. No type of pen may be used. Mark your answers only on the answer sheet. Answers marked in the test booklet will be ignored.
10. Once the test booklets have been distributed, you should check to see that no pages are missing and all pages are readable. You should inform the people in charge immediately in such an event so that your test booklet can be changed.
11. Before you begin to answer the questions, you must write your name, surname, candidate number, and examination hall number on the cover of your booklet. Following the examination, all test booklets are collected and inspected.
12. You may use the blank spaces on the pages of the test booklet as scrap paper for writing or calculating purposes.
13. Remember to give in your test booklet, answer sheet and Examination Entrance Card to the people in charge before you leave the examination hall.

SINAVDA UYULACAK KURALLAR

1. Cep telefonu ile sınava girmek kesinlikle yasaktır. Çağrı cihazı, telsiz, vb. haberleşme araçları ile cep bilgisayarı, saat fonksiyonu dışında fonksiyonu bulunan saat vb. her türlü bilgisayar özelliği bulunan cihazlarla ve ayrıca silah vb. teçhizatla, müsvedde kâğıdı, defter, kitap, sözlük, sözlük işlevi olan elektronik aygıt, hesap makinesi, hesap cetveli, pergel, açölçer, cetvel vb. araçlarla da sınava girmek yasaktır.
2. Bu sınavda verilen cevaplama süresi **100 dakikadır**.
3. Sınav salonunu terk eden aday, her ne sebeple olursa olsun tekrar sınava alınmayacaktır.
4. Sınavın ilk 30 ve son 15 dakikası içinde hiçbir adayın dışarı çıkmasına izin verilmeyecektir.
5. Cevaplama işlemini ilk 30 dakikadan sonra ve son 15 dakikadan önce tamamlarsanız cevap kâğıdınızı, soru kitapçığınızı ve Sınav Giriş ve Belgenizi salon görevlilerine teslim ederek salonu terk edebilirsiniz.
6. Sınav süresince görevlilerle konuşmak ve onlara soru sormak yasaktır. Aynı şekilde görevlilerin de adaylarla yakından ve alçak sesle konuşmaları; ayrıca, adayların birbirinden kalem, silgi vb. şeyleri istemeleri kesinlikle yasaktır.
7. Sınav sırasında görevlilerin her türlü uyarılarına uymak zorundasınız. Gerektiğinde görevliler oturduğunuz yerleri de değiştirebilir. Sınavınızın geçerli sayılması, her şeyden önce sınav kurallarına uymanıza bağlıdır. Kurallara aykırı davranışta bulunur ve yapılacak uyarılara uymazsanız kimliğiniz tutanağa yazılacak ve sınavınız geçersiz sayılacaktır.
8. Sınav sırasında kopya çeken, çekmeye girişen, kopya veren, kopya çekilmesine yardım edenlerin kimlik bilgileri Salon Sınav Tutanağına yazılacak ve bu adayların sınavları geçersiz sayılacaktır. Görevliler kopya çekmeye veya vermeye çalışanları uyarmak zorunda değildir. Sorumluluk size aittir. Sınav sırasında cevap kâğıdınızı başkaları tarafından görülmeyecek şekilde tutmanız sizin için son derece önemlidir.
9. Cevap kâğıdında ilgili alanları doldurmanız gerekmektedir. Cevap kâğıdına yazılacak her türlü yazıda ve yapılacak bütün işaretlemelerde kurşun kalem kullanılacaktır. Tükenmez kalem ve dolma kalem kesinlikle kullanılmayacaktır. Cevapların cevap kâğıdına işaretlenmiş olması gerekir. Soru kitapçığına işaretlenen cevaplar geçerli değildir.
10. Soru kitapçığınızı alır almaz, sayfaların eksik olup olmadığını, kitapçıkta basım hatalarının bulunup bulunmadığını kontrol ediniz. Soru kitapçığının sayfası eksik veya basımı hatalı ise değiştirilmesi için derhâl Salon Başkanına başvurunuz.
11. Cevaplamaya geçmeden önce size verilecek soru kitapçığının üzerinde ayrılan yere adınızı, soyadınızı, Aday numaranızı ve bu salonun Salon Numarasını yazınız.
12. Soru kitapçığının sayfalarındaki boş yerleri müsvedde için kullanabilirsiniz.
13. Sınav salonundan ayrılmadan önce, soru kitapçığınızı, cevap kâğıdınızı ve Sınav Giriş Belgenizi salon görevlilerine teslim etmeyi unutmayınız.